

SPECIFICATION

REFOND P/N

RF-MTR**S50-Q1

Mass Product

Contents

1. LED Module Description	
2.LED Module Specification	
2.1 Optical-electrical Characteristics(Absolute Maximum Ratings At Ts=25)	.4
2.2 LED Module Schematic And Interface Definition	6
2.3 LED Module rule of naming	6
3. Product Specification	
3.1 Outline Dimension	7
4. LED Module Reliability Test	
5. LED Module Materials Performance Test And Method At Ta=25	
6.Packing Criterion	
6.1 Package Diagram /	10
6.2 Carton Dimensions/	!
6.3 Module Assembling Instruction /	10
7. Handling Precautions	

1. LED Module Description

- **EMC3030 LED**
Using EMC3030 LEDs, with high luminous efficiency and low heat, no mercury and other harmful elements, belong to environmentally-friendly products
- **150lm/W**
Modules maximum luminous efficiency is up to 150lm/W
- **LED 6**
The temperature difference to 6 between light source and heatsink, improve reliability of modules
- **30 LED 65**
Using strong heatsink, when the ambient temperature 30 LED pad temperature below 65
- **UV**
Using high-quality lens with anti-UV and uniform light distribution, also conform to road lighting requirements
- **IP66**
Module outer shell waterproof up to IP 66, can pass boiling red ink test
- **CSA 016-2015 M15**
Outer shape meets CSA 016-2015 design, fit to all lighting fixtures and assembling with M15 waterproof connector is simple and convenient
- **/**
Application street lighting, airport lighting, port lighting, gymnasium lighting, square lighting

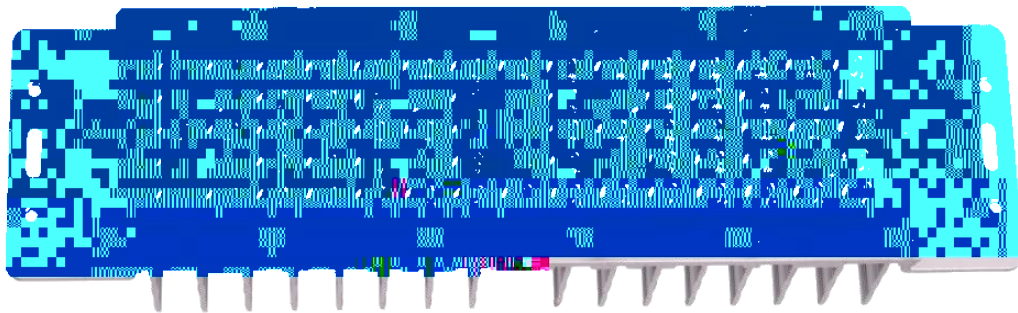

2.LED Module Specification

2.1 Optical-electrical Characteristics(Absolute Maximum Ratings At Ts=25)

Tab.2-1 Optical-electrical Characteristics

	50	48	1040	7250	145		

5790-6575K

55°/150°/8
0°/150°

Absolute Maximum Ratings at Ts=25°C

Parameter	Symbol	Rating	Units
Forward Current	I _F	1060	mA
Peak Forward Current	I _{FP}	1200	mA
Reverse Voltage	V _R	5	V
Electrostatic Discharge	E _{SD}	2000	V
Operating Temperature	T _{OPR}	-40 ~ +85	
Storage Temperature	T _{STG}	-40 ~ +100	
unction temperature	T _J	115	

2.2 LED Module Schematic And Interface Definition

Fig.2-2ED Module connection

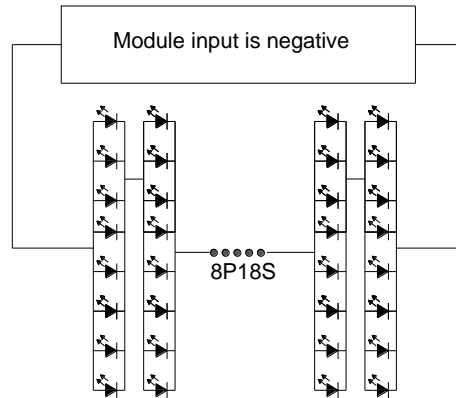

2.3 LED Module rule of naming :

RF MT R 40 W S 50 Q 1

1

Refond version number (1: the first version)

Q

module emitting light way Q Outdoor module

50

50W

LED module power: 50 LED module is 50W

S: 75 S 70

LED module CRI S: 75 70

W EMC3030

LED Package type W EMC3030

40 3700-4275K

LED Module CCT 40 3700-

3.1 Outline Dimension

C

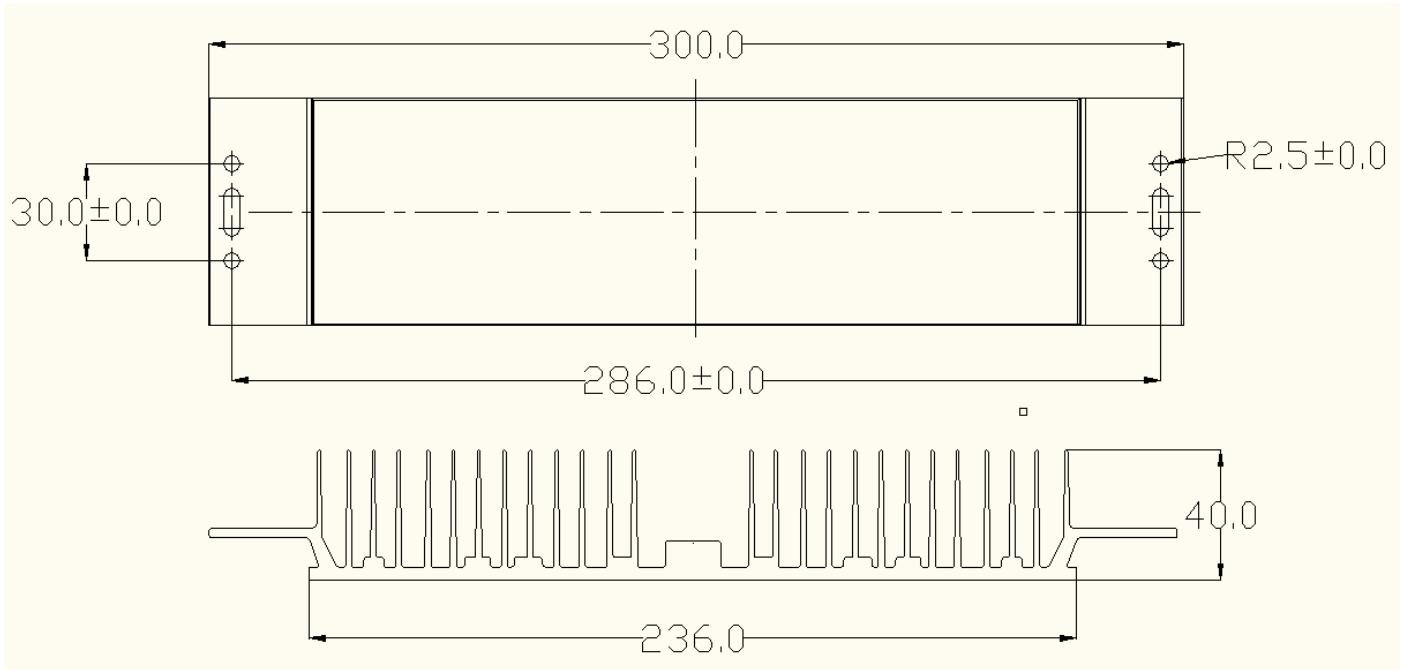

	Dimension	Specification	Tolerance
L	Module Length	300	±0.3
W	Module Width	70	±0.3
H2	Height of Module	40	±0.3

4. LED Module Reliability Test

Tab 4-1 Light Bar Reliability Test

Test Item/	Test Conditions/	Test Time/	Number Of Test/	Judgement Criterions/
Operating Life At Room Temperature/	$T_A=25$ $I_F=180\text{mA}$ $T_j<115$	500Hrs	0/6	1. $V_f<110\%$, $\text{CIE } x/ y<0.015$ 2.No catastrophic failure
Operating Life At High Temperature/	$T_A=60$ $I_F=180\text{mA}$ $T_j<115$	500Hrs	0/6	
Operating Life At High Temperature And Humidity/	60 $R_H=90\%$ $I_F=180\text{mA}$ $T_j<115$	500Hrs	0/6	
Thermal Shock/	-40 15min 85 15min	100 cycle	0/6	No Dead LED

Notes

voltage distribution, heat dissipation and others.

5. LED Module Materials Performance Test And Method At $T_a=25$

Tab 5-1 Light Bar Materials Performance Test And Method Ta=25

Test Item	Test Conditions	Test Methods
LED Optical-electrical Characteristics LED	Compliance With Specifications/	Integrating Sphere/
Connector Pull Force/		Notes/
LED Push & Pull Force LED		
LED Welding Standards LED	Offset Specifications/ X Shift /X Y Shift/ Y Angle/	

Notes

Fig 5-1 Push & Pull Test Equipment

Fig 7-2 Push & Pull Test Method

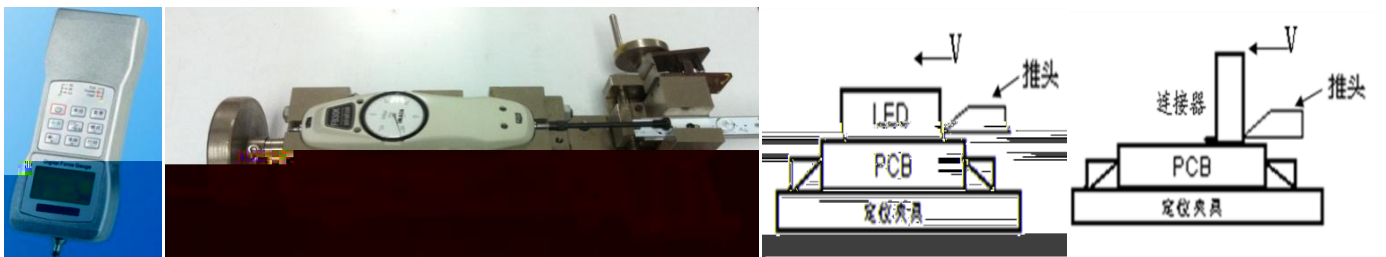

6.Packing Criterion

6.1 Package Diagram /

Fig 8-1 Package Diagram /

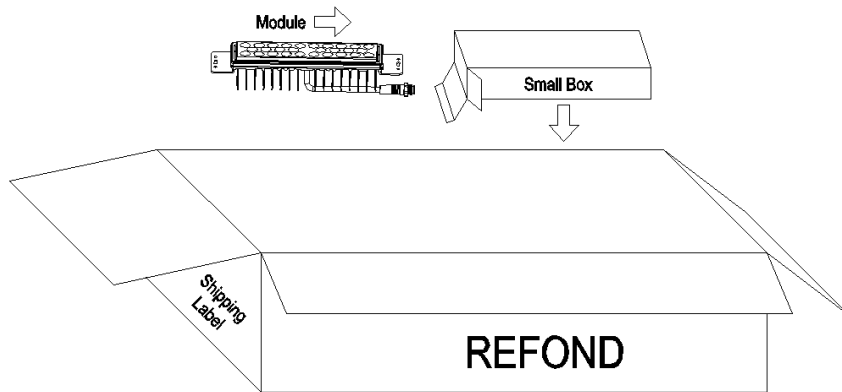

6.2 Carton silk printing/

REFOND LOGO Pay attention to identify

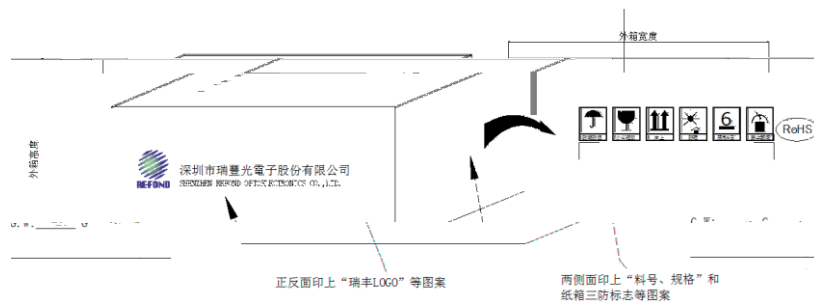

6.3 Module Assembling Instruction



A.
Assembling Instruction
from the bottom

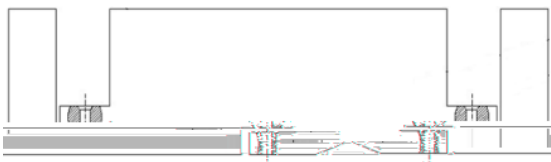

B.
Assembling Instruction

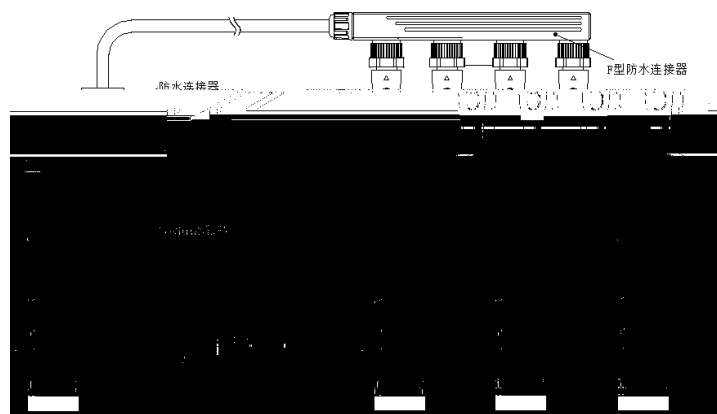

C.
Installation instruction of light parallel circuit from the top

7. Handling Precautions

(1) LED operating environment and sulfur element composition cannot be over 100PPM in the LED mating usage material. This is provided for informational purposes only and is not a warranty or endorsement.LED

(2) In order to prevent external material from getting into the inside of LED, which may cause the malfunction of LED, the single content of Bromine element is required to be less than 900PPM,the single content of Chlorine element is required to be less than 900PPM,the total content of Bromine element and Chlorine element in the external materials of the application products is required to be less than 1500PPM. This is provided for informational purposes only and is not a warranty or endorsement.

(3) VOCs (Volatile organic compounds) emitted from materials used in the construction of fixtures can penetrate silicone encapsulants of LEDs and discolor when exposed to heat and photonic energy. The result can be a significant loss of light output from the fixture. Knowledge of the properties of the materials selected to be used in the construction of fixtures can help prevent these issues. Refond advises against the use of any chemicals or materials that have been found or are suspected to have an adverse affect on device performance or reliability. To verify compatibility, Refond recommends that all chemicals and materials be tested in the specific application and environment for which they are intended to be used. Attaching LEDs, do not use adhesives that outgas organic vapor.

(4) Handle the component along the side surface by using forceps or appropriate tools; do not directly touch or Handle the silicone lens surface, it may damage the internal circuitry.

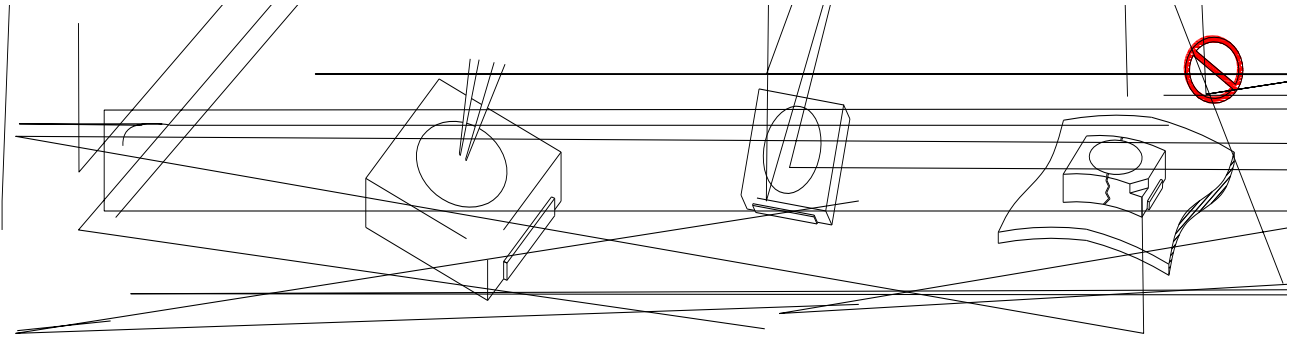

(5) In designing a circuit, the current through each LED can not be exceed the absolute maximum rating specified for each LED. In the mean while, resistors for protection should be applied, otherwise slight voltage shift will cause big current change, burn out may happen. The driving circuit must be designed to allow forward voltage only when it is ON or OFF. If the reverse voltage is applied to LED, migration can be generated resulting in LED damage.

(6) Thermal Design is paramount importance because heat generation may result in the Characteristics decline, such as brightness decreased, Color change and so on. Please consider the heat generation of the LEDs when making the system design.LED

(7) Compared to standard encapsulants, silicone is generally softer, and the surface is more likely to attract dust , requiring special care during processing. In cases where a minimal level of dirt and dust particles cannot be guaranteed, a suitable cleaning solution must be applied to the surface after the soldering of components. Refond suggests using isopropyl alcohol for cleaning. In case other solvents are used, it must be assured that these solvents do not dissolve the package or resin. Ultrasonic cleaning is not recommended. Ultrasonic cleaning may cause damage to the LED.

(8) Similar to most Solid state devices; LEDs are sensitive to Electro-Static Discharge (ESD) and Electrical Over Stress (EOS).

9>.NO warping or twisting the Light Bar more than 10°. Forbidding holding the LED part or connector part when handling.



(10) Other points for attention, please refer to our relevant information.

Version History/

Date	Revisor	Version	Verifier	Remarks
2021-08-10		E/1		The first edition



Declare

This specification is written both in English and in Chinese and the latter is formal.