

SPECIFICATION

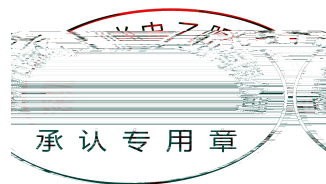

General Description



1. D c

1.1 General Description

1.2 F a

1.3 A ca

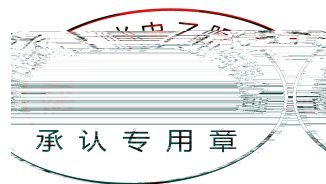

1.4 Pac a D

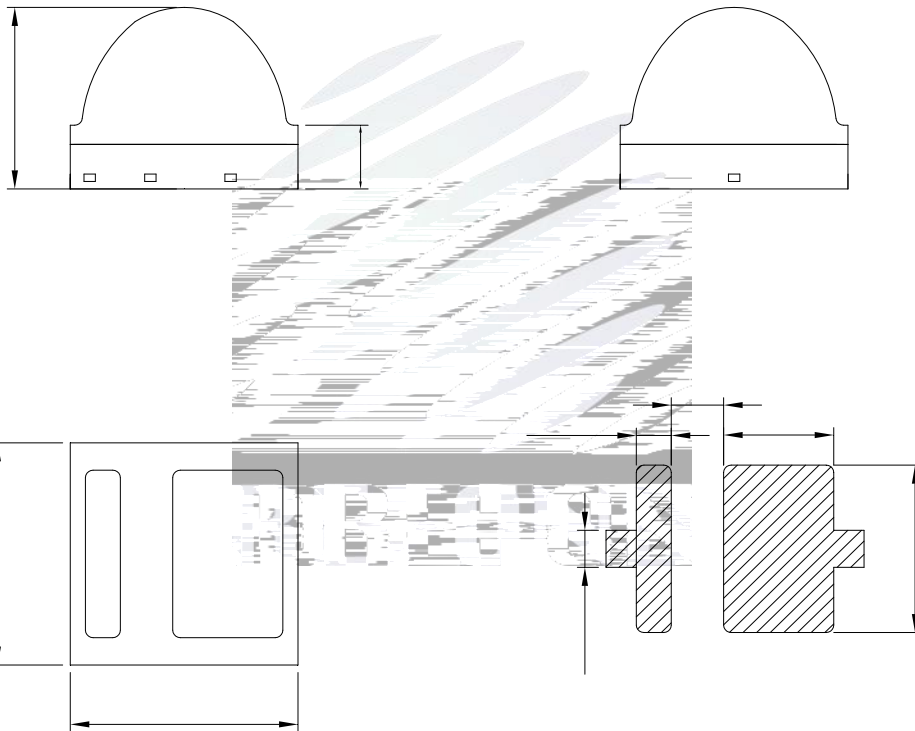
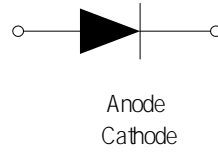
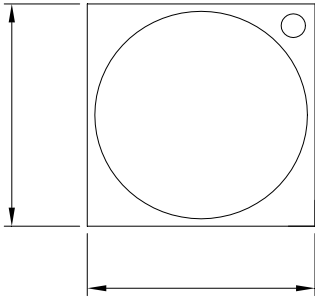

±

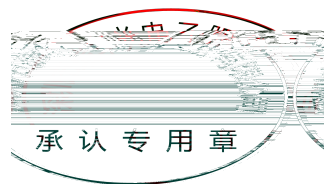

1.5 P d c P a a

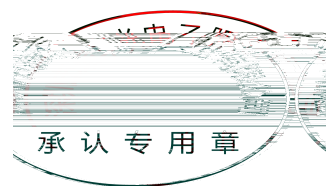

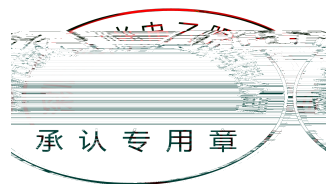

1.6 B Ra O F a d V a a d L F (IF=350 A)
 BIN (IF=350 A)

30M

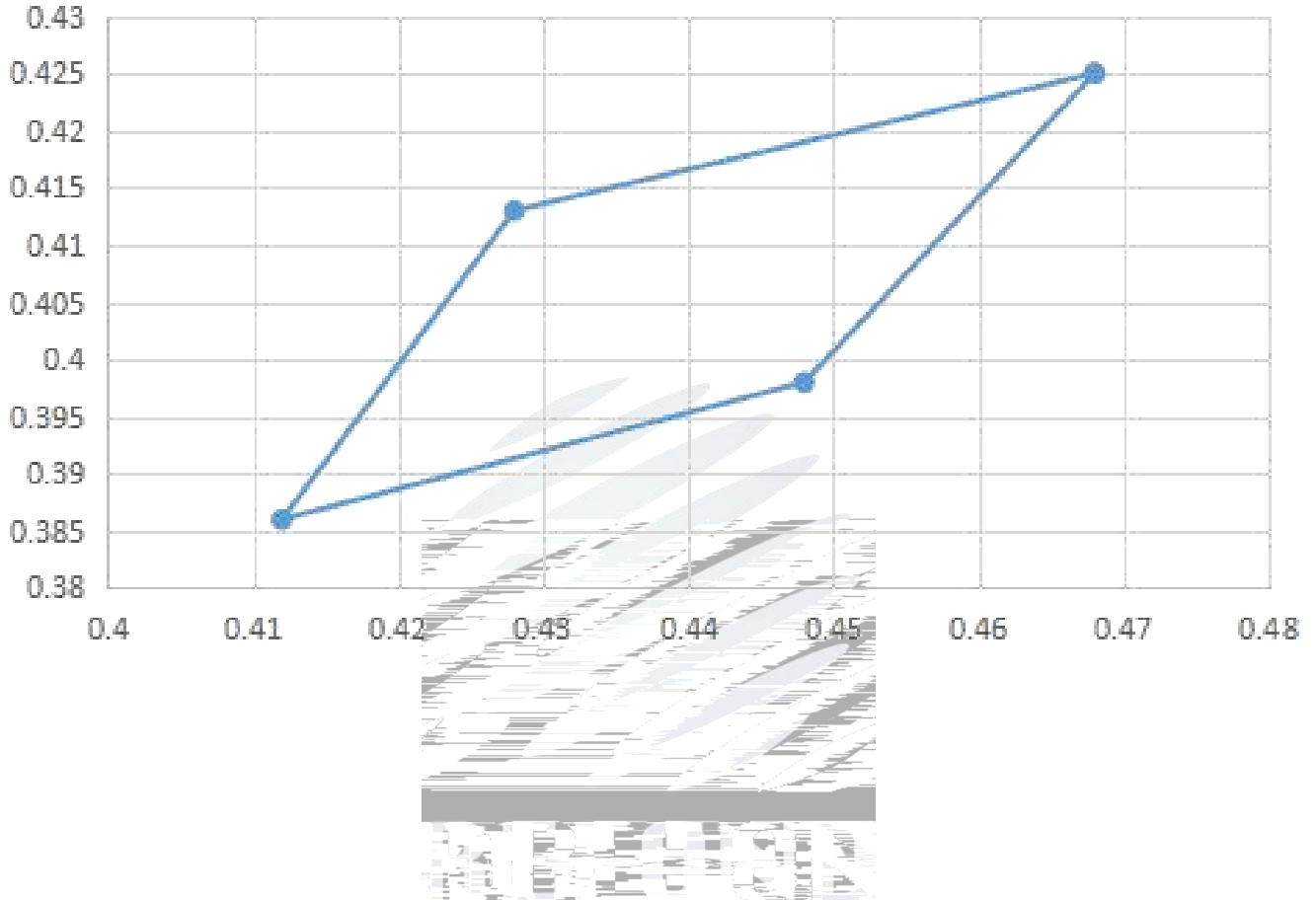

B da a

B C d	X1	Y1	X2	Y2	X3	Y3	X4	Y4
30M								

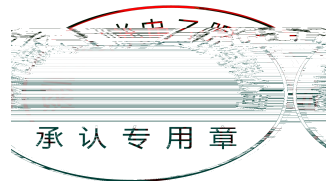

1.7 T ca O ca C a ac c C

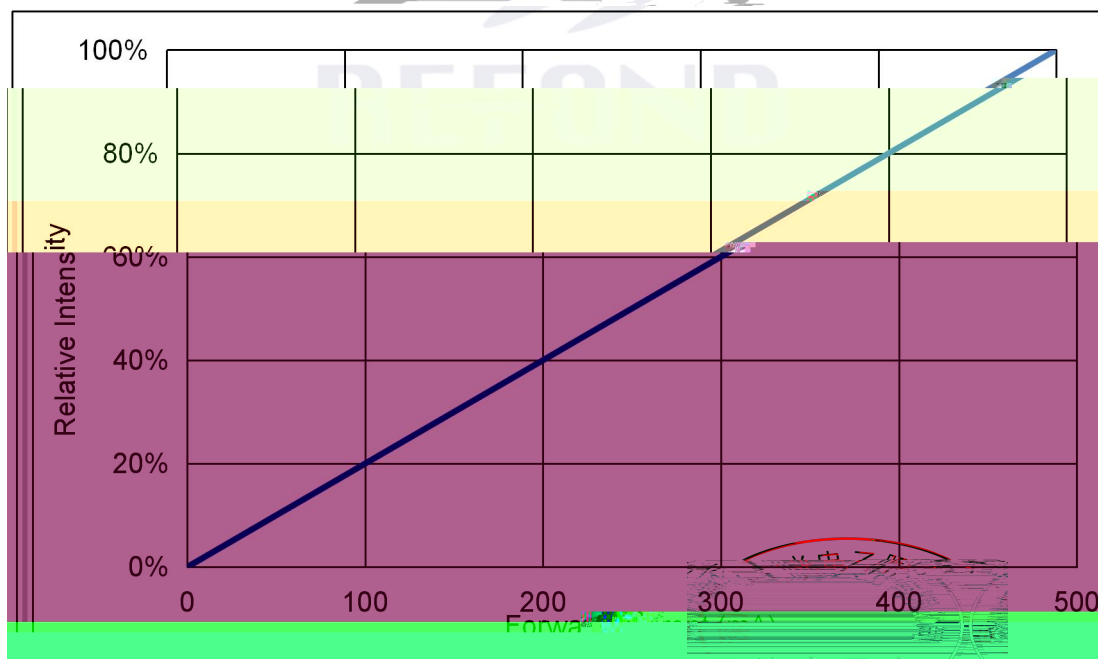
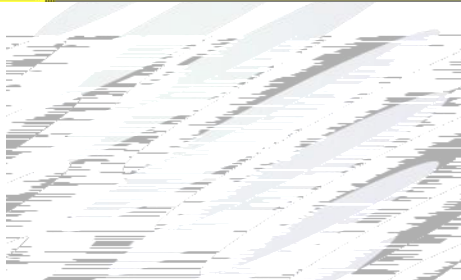
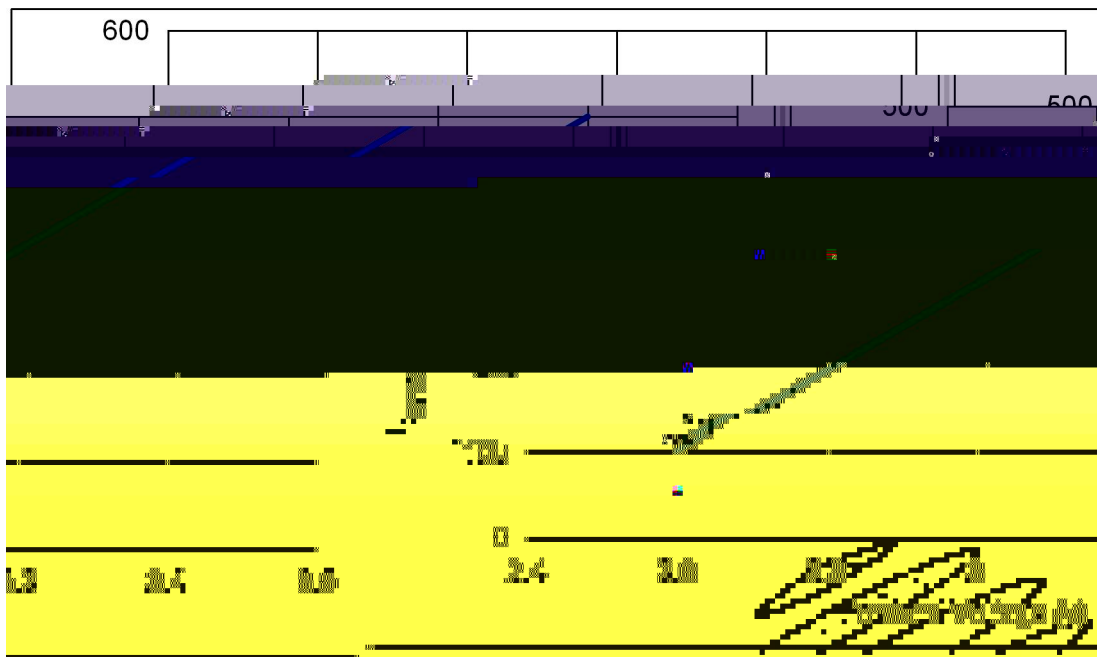

承认专用章

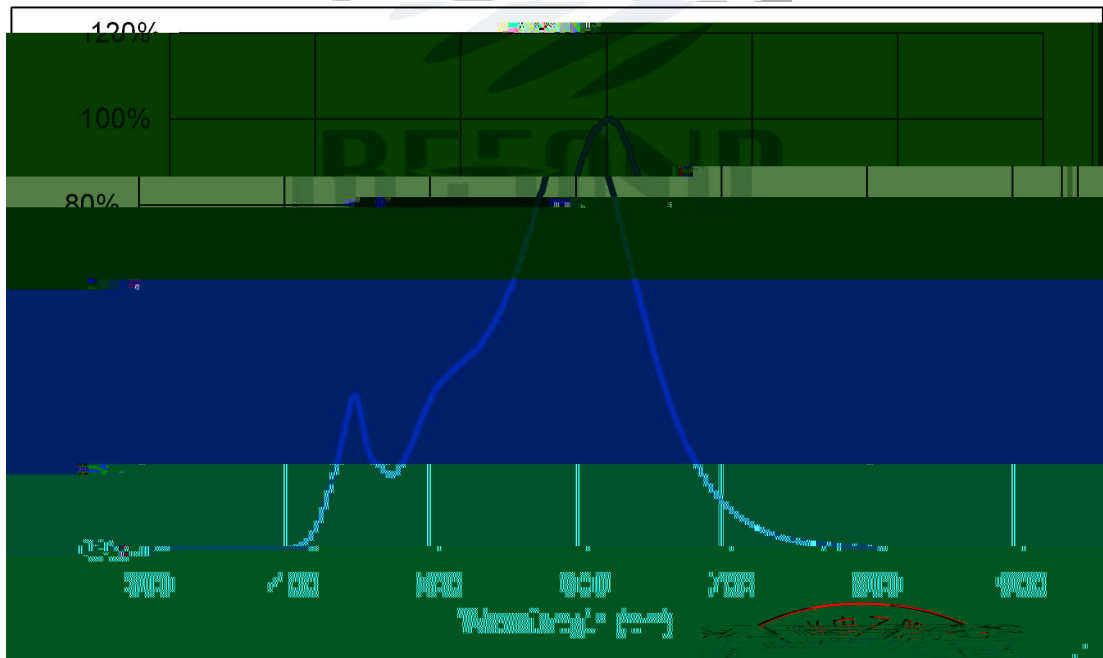
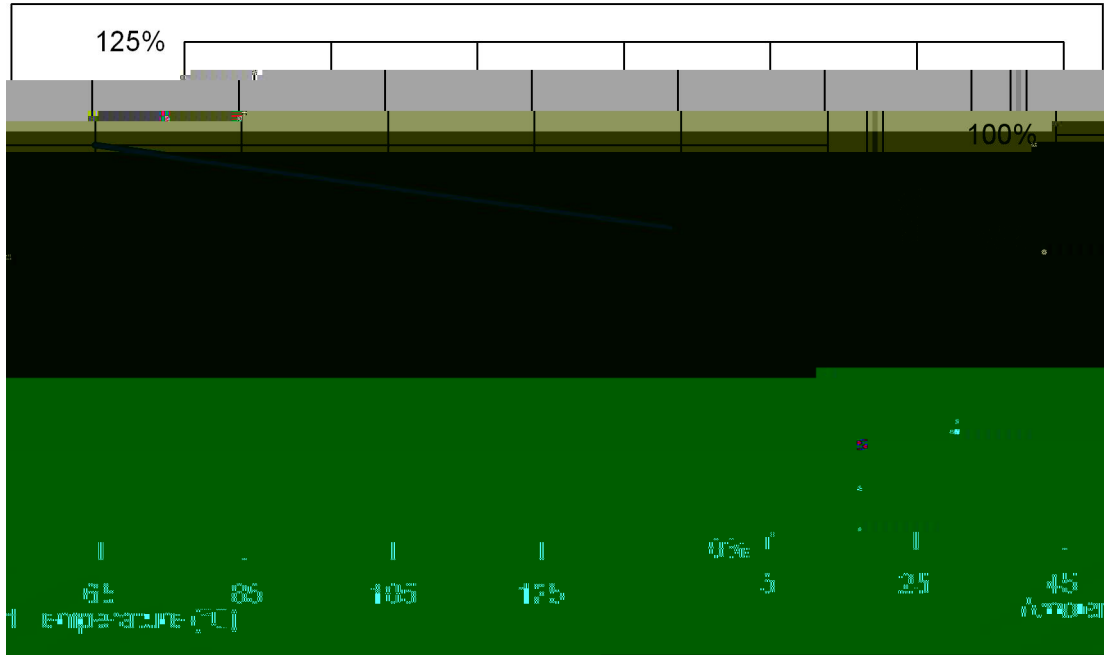

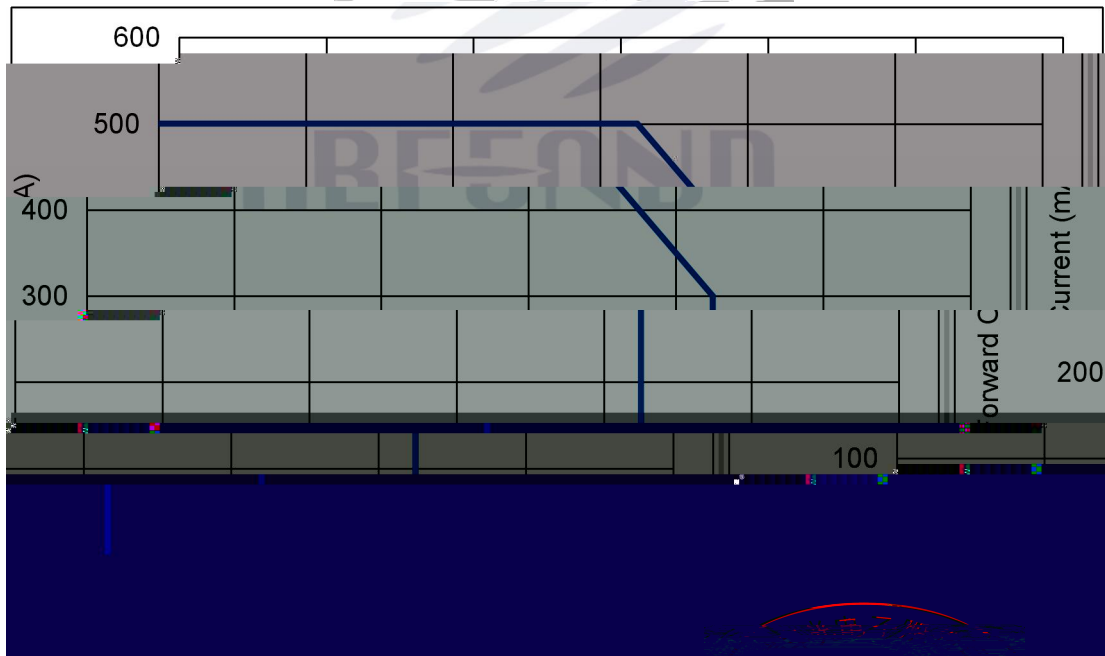
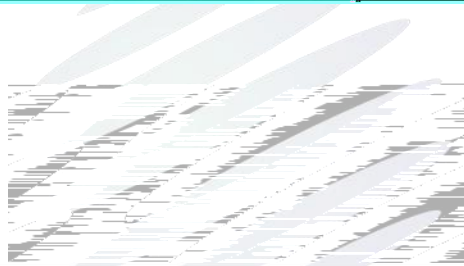
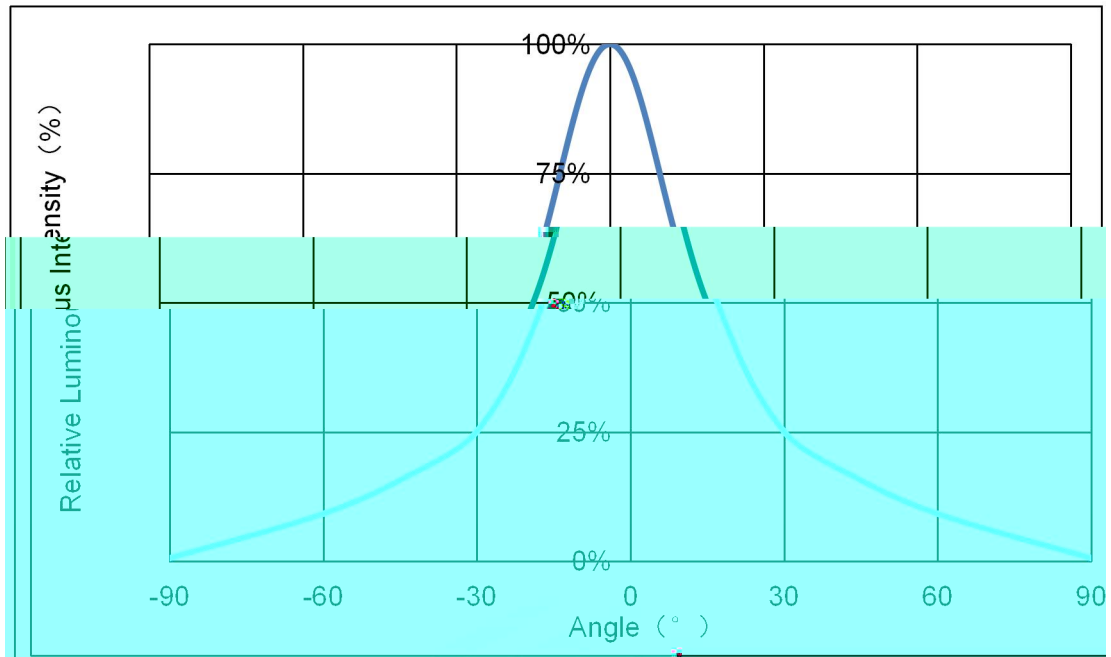

2. Pac a

2.1 Pac a S c ca

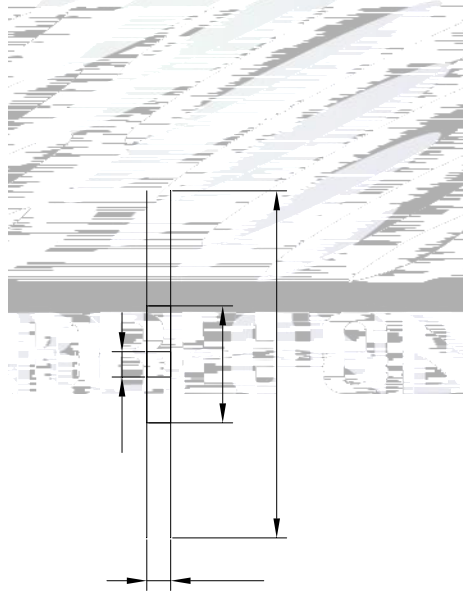
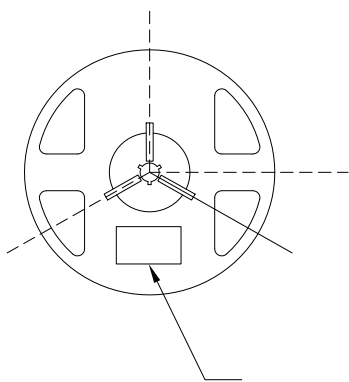
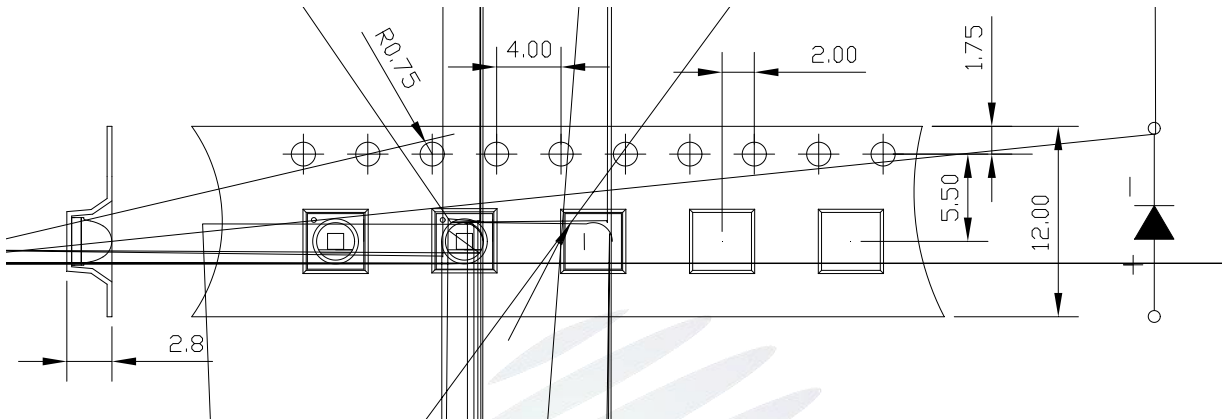

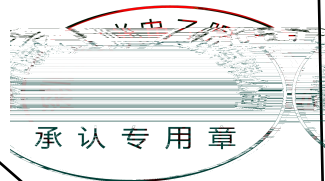
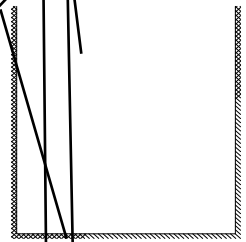
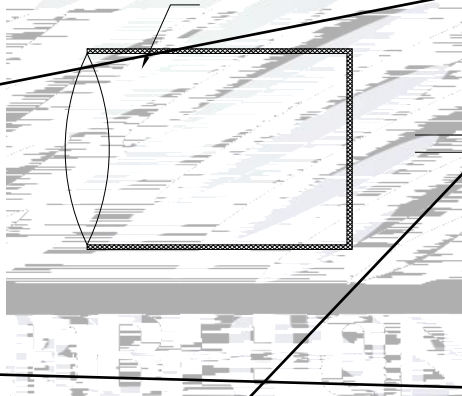
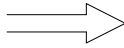
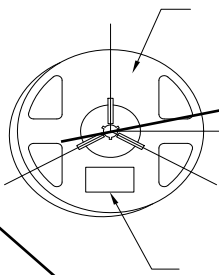

2.4 R ab T I A d C d

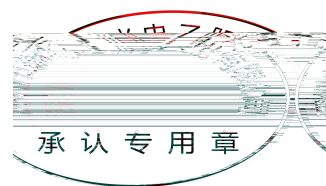

2.5 C aF J d Da a

Luminous Flux				

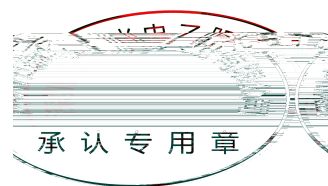
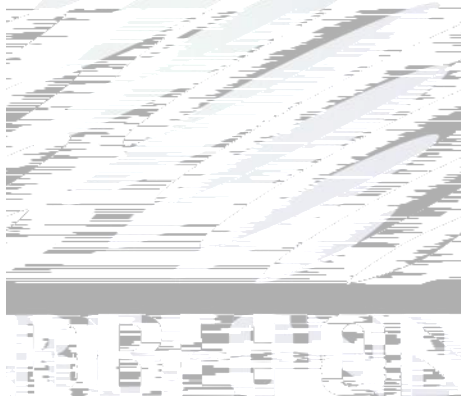

,Û, ,?#h, Û\$µ

P ^'ò @/è BcX...

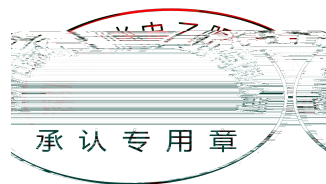

4. Ha d P ca

4.1 Ha d P ca

